

## 3" DIAPHRAGM PUMP 1:1 RATIO, METALLIC



**READ THIS MANUAL CAREFULLY BEFORE INSTALLING,  
OPERATING OR SERVICING THIS EQUIPMENT.**

**It is the responsibility of the employer to place this information in the hands of the operator. Keep for future reference.**

### SERVICE KITS

Refer to Model Description Chart to match the pump material options.

637421 for air section repair (see page 6).

637303-TA for fluid section repair (see page 4).

### PUMP DATA

<b>Models</b> .....	670106
<b>Pump Type</b> .....	Air Operated Double Diaphragm
<b>Material</b> .....	see Model Description Chart
<b>Weight</b> .....	245.60 lbs (111.4 kgs)
<b>Maximum Air Inlet Pressure</b> .....	120 p.s.i.g. (8.3 bar)
<b>Maximum Material Inlet Pressure</b> .....	10 p.s.i.g. (0.69 bar)
<b>Maximum Outlet Pressure</b> .....	120 p.s.i.g. (8.3 bar)
<b>Maximum Flow Rate</b> .....	237 g.p.m. (897 l.p.m.)
(flooded inlet) .....	275 g.p.m. (1041 l.p.m.)
<b>Displacement / Cycle @ 100 p.s.i.g.</b> ..	2.8 gal. (10.6 lit.)
<b>Maximum Particle Size</b> .....	3/8" dia. (9.5 mm)
<b>Maximum Temperature Limits (diaphragm / ball / seal / seat material)</b>	
Santoprene® .....	-40° to 225° F (-40° to 107° C)
PTFE .....	40° to 225° F (4° to 107° C)
<b>Dimensional Data</b> .....	see page 8
<b>Noise Level @ 70 p.s.i., 50 c.p.m.</b> ① ...	83.0 db(A)②

① Tested with 67263 muffler assembly installed.

② The pump sound pressure levels published here have been updated to an Equivalent Continuous Sound Level ( $L_{Aeq}$ ) to meet the intent of ANSI S1.13-1971, CAGI-PNEUROPS 55.1 using four microphone locations.

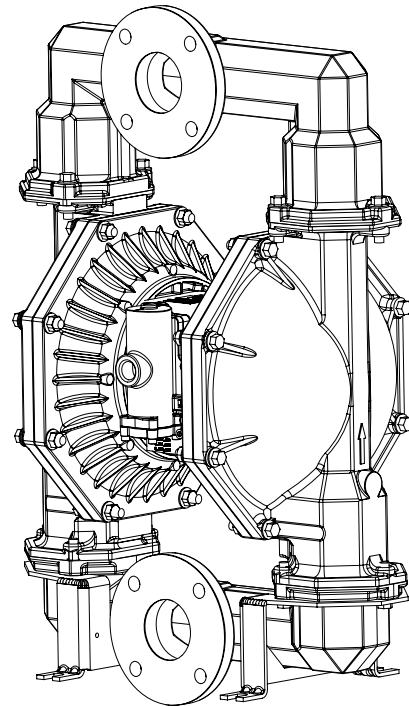

Figure 1

### MODEL DESCRIPTION CHART

**Air Motor / Air Cap Material**

Aluminum / Aluminum

**Fluid Connection**

3" A.N.S.I. / DIN Flange

**Fluid Cap & Manifold Material**

Stainless Steel

**Hardware Material**

Stainless Steel

**Seat Material**

316 Stainless Steel

**Ball Material**

PTFE

**Diaphragm Material**

Santoprene

## OPERATING AND SAFETY PRECAUTIONS

READ, UNDERSTAND AND FOLLOW THIS INFORMATION TO AVOID INJURY AND PROPERTY DAMAGE.



**⚠️ WARNING** EXCESSIVE AIR PRESSURE. Can cause personal injury, pump damage or property damage.

- Do not exceed the maximum inlet air pressure as stated on the pump model plate.
- Be sure material hoses and other components are able to withstand fluid pressures developed by this pump. Check all hoses for damage or wear. Be certain dispensing device is clean and in proper working condition.

**⚠️ WARNING** STATIC SPARK. Can cause explosion resulting in severe injury or death. Ground pump and pumping system.

- Sparks can ignite flammable material and vapors.
- The pumping system and object being sprayed must be grounded when it is pumping, flushing, recirculating or spraying flammable materials such as paints, solvents, lacquers, etc. or used in a location where surrounding atmosphere is conducive to spontaneous combustion. Ground the dispensing valve or device, containers, hoses and any object to which material is being pumped.
- Use the pump ground lug provided. Use ARO® part no. 66885-1 ground kit or connect a suitable ground wire (12 ga. minimum) to a good earth ground source.
- Secure pump, connections and all contact points to avoid vibration and generation of contact or static spark.
- Consult local building codes and electrical codes for specific grounding requirements.
- After grounding, periodically verify continuity of electrical path to ground. Test with an ohmmeter from each component (e.g., hoses, pump, clamps, container, spray gun, etc.) to ground to insure continuity. Ohmmeter should show 0.1 ohms or less.
- Submerge the outlet hose end, dispensing valve or device in the material being dispensed if possible. (Avoid free streaming of material being dispensed.)
- Use hoses incorporating a static wire.
- Use proper ventilation.
- Keep inflammables away from heat, open flames and sparks.
- Keep containers closed when not in use.

**⚠️ WARNING** Pump exhaust may contain contaminants. Can cause severe injury. Pipe exhaust away from work area and personnel.

- In the event of a diaphragm rupture, material can be forced out of the air exhaust muffler.
- Pipe the exhaust to a safe remote location when pumping hazardous or inflammable materials.
- Use a grounded 1" minimum i.d. hose between the pump and the muffler.

**⚠️ WARNING** HAZARDOUS PRESSURE. Can result in serious injury or property damage. Do not service or clean pump, hoses or dispensing valve while the system is pressurized.

- Disconnect air supply line and relieve pressure from the system by opening dispensing valve or device and / or carefully and slowly loosening and removing outlet hose or piping from pump.

**⚠️ WARNING** HAZARDOUS MATERIALS. Can cause serious injury or property damage. Do not attempt to return a pump to the factory or service center that contains hazardous material. Safe handling practices must comply with local and national laws and safety code requirements.

- Obtain Material Safety Data Sheets on all materials from the supplier for proper handling instructions.

**⚠️ WARNING** EXPLOSION HAZARD. Models containing aluminum parts cannot be used with 1,1,1-trichloroethane, methylene chloride or other halogenated hydrocarbon solvents which may react and explode.

- Check pump motor section, fluid caps, manifolds and all wetted parts to assure compatibility before using with solvents of this type.

**⚠️ WARNING** MISAPPLICATION HAZARD. Do not use models containing aluminum wetted parts with food products for human consumption. Plated parts can contain trace amounts of lead.

**⚠️ CAUTION** Verify the chemical compatibility of the pump wetted parts and the substance being pumped, flushed or recirculated. Chemical compatibility may change with temperature and concentration of the chemical(s) within the substances being pumped, flushed or circulated. For specific fluid compatibility, consult the chemical manufacturer.

**⚠️ CAUTION** Maximum temperatures are based on mechanical stress only. Certain chemicals will significantly reduce maximum safe operating temperature. Consult the chemical manufacturer for chemical compatibility and temperature limits. Refer to PUMP DATA on page 1 of this manual.

**⚠️ CAUTION** Be certain all operators of this equipment have been trained for safe working practices, understand it's limitations, and wear safety goggles / equipment when required.

**⚠️ CAUTION** Do not use the pump for the structural support of the piping system. Be certain the system components are properly supported to prevent stress on the pump parts.

- Suction and discharge connections should be flexible connections (such as hose), not rigid piped, and should be compatible with the substance being pumped.

**⚠️ CAUTION** Prevent unnecessary damage to the pump. Do not allow pump to operate when out of material for long periods of time.

- Disconnect air line from pump when system sits idle for long periods of time.

**⚠️ CAUTION** Use only genuine ARO replacement parts to assure compatible pressure rating and longest service life.

**NOTICE** Replacement warning labels are available upon request: "Static Spark" pn \ 93616-1, Diaphragm Rupture" pn \ 93122.

- ⚠ WARNING** = Hazards or unsafe practices which could result in severe personal injury, death or substantial property damage.
- ⚠ CAUTION** = Hazards or unsafe practices which could result in minor personal injury, product or property damage.
- NOTICE** = Important installation, operation or maintenance information.

## GENERAL DESCRIPTION

The ARO diaphragm pump offers high volume delivery even at low air pressure. ARO pumps feature stall resistant design, modular air motor / fluid sections.

Air operated double diaphragm pumps utilize a pressure differential in the air chambers to alternately create suction and a positive fluid pressure in the fluid chambers, ball checks insure a positive flow of fluid.

Pump cycling will begin as air pressure is applied and it will continue to pump and keep up with the demand. It will build and maintain line pressure and will stop cycling once maximum line pressure is reached (dispensing device closed) and will resume pumping as needed.

## AIR AND LUBE REQUIREMENTS

**⚠ WARNING EXCESSIVE AIR PRESSURE. Can cause pump damage, personal injury or property damage.**

- A filter capable of filtering out particles larger than 50 microns should be used on the air supply. There is no lubrication required other than the "O" ring lubricant which is applied during assembly or repair.
- If lubricated air is present, make sure that it is compatible with the "O" rings and seals in the air motor section of the pump.

## OPERATING INSTRUCTIONS

- Always flush the pump with a solvent compatible with the material being pumped if the material being pumped is subject to "setting up" when not in use for a period of time.
- Disconnect the air supply from the pump if it is to be inactive for a few hours.
- The outlet material volume is governed not only by the air supply, but also by the material supply available at the inlet. The material supply tubing should not be too small or restrictive. Be sure not to use hose which might collapse.
- When the diaphragm pump is used in a forced-feed (flooded inlet) situation, it is recommended that a "check valve" be installed at the air inlet.
- Secure the diaphragm pump legs to a suitable surface to insure against damage by vibration.

## MAINTENANCE

Refer to the part views and descriptions as provided on pages 4 through 7 for parts identification and service kit information.

- Certain ARO "Smart Parts" are indicated which should be available for fast repair and reduction of down time.
- Service kits are available to service two separate diaphragm pump functions: 1. AIR SECTION, 2. FLUID SECTION. The Fluid Section is divided further to match typical active Material Options.
- Provide a clean work surface to protect sensitive internal moving parts from contamination from dirt and foreign matter during service disassembly and reassembly.
- Keep good records of service activity and include the pump in preventive maintenance program.
- Before disassembling, empty captured material in the outlet manifold by turning the pump upside down to drain material from the pump.

## PARTS LIST / 670106 FLUID SECTION

★ 637303-TA fluid section service kits include: Balls (item 22), diaphragms (item 7) plus items 19, 70, 144, 175 (listed below) plus 174 and 94276 Lubriplate® FML-2 grease (page 6).

### PARTS LIST

Item	Description (size)	Qty	Part No.	[Mtl]
1	Rod	(1)	94984	[C]
5	Backup Washer	(2)	66167	[SS]
6	Diaphragm Screw	(2)	94094	[SS]
★ 7	Diaphragm	(2)	94091-A	[Sp]
15	Fluid Cap	(2)	94107	[SS]
★ 19	"O" Ring (3/16" x 5" o.d.)	(4)	Y328-350	[T]
21	Seat	(4)	94113	[SS]
★ 22	Ball (3-1/4" diameter)	(4)	94103-T	[T]
26	Screw (M12 x 1.75 - 6g x 45 mm)	(12)	94412-2	[SS]
27	Screw (M12 x 1.75 - 6g x 60 mm)	(16)	94991	[SS]
29	Nut (M12 x 1.75 - 6h)	(16)	95053	[SS]

Item	Description (size)	Qty	Part No.	[Mtl]
32	Leg	(2)	94703-2	[SS]
43	Ground Lug (see page 7)	(1)	93004	[Co]
60	Inlet Manifold	(1)	96785	[SS]
61	Outlet Manifold	(1)	96784	[SS]
68	Air Cap	(1)	94030-1	[A]
69	Air Cap	(1)	94030-2	[A]
★✓ 70	Gasket	(2)	94100	[B]
131	Screw (M10 x 1.5 - 6g x 120 mm)	(4)	94531	[C]
★✓ 144	"U" Cup (3/16" x 1-3/8" o.d.)	(2)	Y186-51	[B]
★✓ 175	"O" Ring (3/32" x 1" o.d.)	(2)	Y325-117	[B]
✓ 180	Gasket (0.406" i.d. x 0.031" thick)	(4)	94098	[Co]

✓ Indicates items included in 637421 air section repair kit.

### FLUID SECTION DISASSEMBLY

1. Remove top manifold(s).
2. Remove (22) balls, (19) "O" rings and (21) seats.
3. Remove (15) fluid caps.
4. Remove (6) diaphragm screws, (7) diaphragms and (5) backup washers.

NOTE: Do not scratch or mar the surface of (1) diaphragm rod.

### FLUID SECTION REASSEMBLY

SERVICE NOTE: ARO pn 94094-TIL diaphragm assembly tool is recommended for use when reassembling the pump.

- Reassemble in reverse order.
- Clean and inspect all parts. Replace worn or damaged parts with new parts as required.
- Lubricate (1) diaphragm rod and (144) "U" cup with Lubriplate FML-2 grease. (94276 grease packet is included in service kit.)
- Be certain the diaphragm assembly bottoms out on the (1) rod.
- Re-check torque settings after pump has been re-started and run a while.

### ASSEMBLING DIAPHRAGM ASSEMBLY

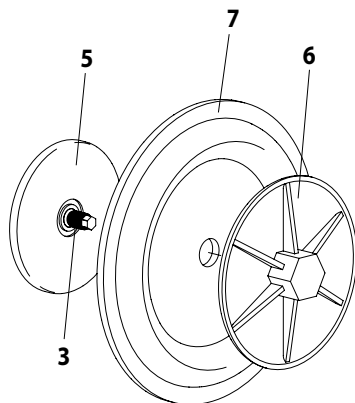

**Diaphragm assembly: (3) Thread, (5) Back-up Washer, (6) Diaphragm Screw, (7) Diaphragm.**

MATERIAL CODE	
[A]	= Aluminum
[B]	= Nitrile
[C]	= Carbon Steel
[Co]	= Copper
[Sp]	= Santoprene
[SS]	= Stainless Steel
[T]	= PTFE

1. Apply Loctite 271 Threadlocker to thread (3) on (5) Back-up Washer.
2. Insert (7) Diaphragm insuring seal bead on (7) Diaphragm is in the groove on (5) Back-up Washer.
3. Thread (6) Diaphragm Screw onto the stud on (5) Back-up Washer.

Applying a light coating of Lubriplate FML-2 Grease to the surfaces of (6) Diaphragm Screw and (7) Diaphragm, being careful not to get grease on the Loctite prepared area. This will reduce friction during tightening of the assembly. Tighten 65-70 Ft-Lbs.

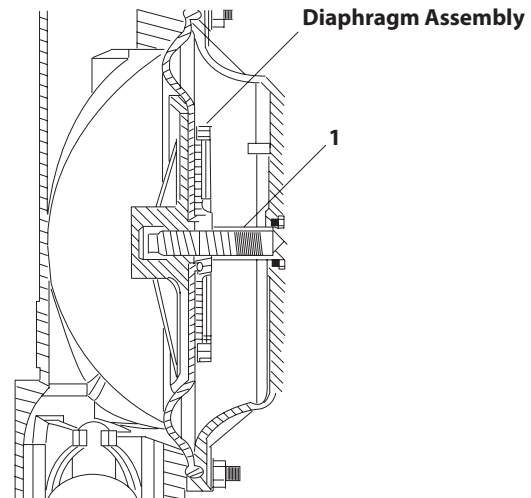

1. Screw the two Diaphragm Assemblies to (1) Rod.
2. Tighten Diaphragm Assemblies to 65-70 Ft-Lbs. Be sure to torque both sides.

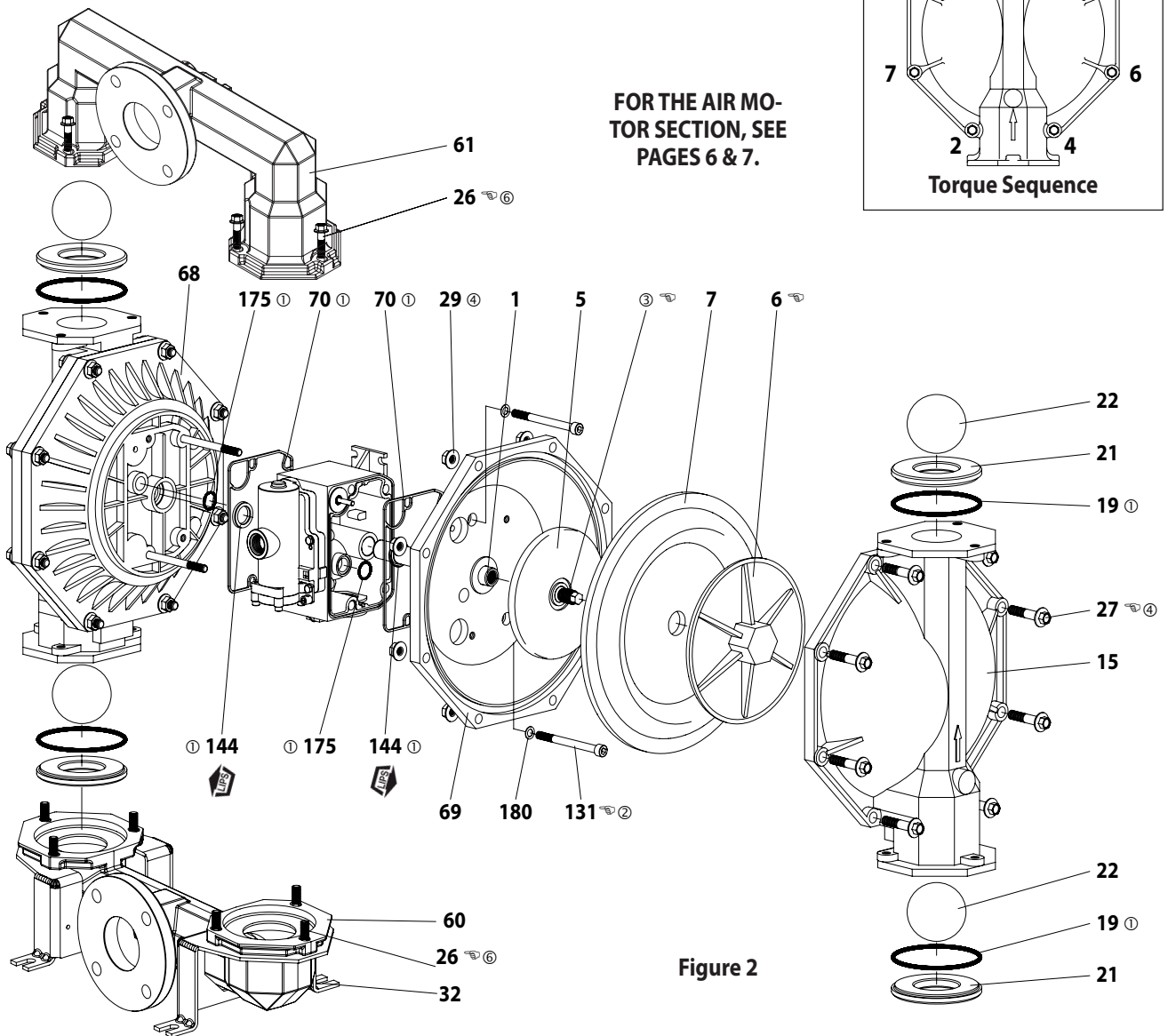

Figure 2

**ASSEMBLY TORQUE REQUIREMENTS**

NOTE: DO NOT OVERTIGHTEN FASTENERS.  
ALL FASTENERS ARE METRIC.

- (5) Stud, 90 ft lbs (122 Nm) maximum.
- (6) Diaphragm screw, 65 - 70 ft. lbs (88.1 - 94.9 Nm).
- (26) Screw, 60 - 70 ft lbs (81.3 - 94.9 Nm).
- (27) Screw, 60 - 70 ft lbs (81.3 - 94.9 Nm).
- (131) Screw, 35 - 40 ft lbs (47.5 - 54.2 Nm).

**LUBRICATION / SEALANTS**

- ① Apply Lubriplate FML-2 grease (94276) to all "O" rings, "U" cups and mating parts.
- ② Apply Loctite® 242® to threads at assembly.
- ③ Apply Loctite 271™ to threads at assembly.
- ④ Apply anti-seize compound to threads and bolt and nut flange heads which contact pump case when using stainless steel fasteners.

NOTE: Lubriplate FML-2 is a white food grade petroleum grease.



## PARTS LIST / 670106 AIR MOTOR SECTION

✓ Indicates parts included in 637421 air section repair kit.

### AIR MOTOR PARTS LIST

Item	Description (size)	Qty	Part No.	[Mtl]
101	Center Body	(1)	94028	[A]
103	Bushing	(1)	94092	[D]
105	Screw (M6 x 1 - 6g x 20 mm)	(4)	95887	[SS]
111	Spool	(1)	95651	[D]
118	Actuator Pin (0.250" x 2.276" long)	(2)	94083	[SS]
121	Sleeve	(2)	94084	[D]
127	90° St. Elbow (1-1/2 - 11-1/2 N.P.T.)	(1)	94860	[C / I]
128	Set Screw (1/4" - 20 x 1/4")	(2)	Y29-42-S	[SS]
✓ 132	Gasket	(1)	94099	[B]
133	Lockwasher (1/4")	(3)	Y117-416-C	[C]
134	Screw (M6 x 1 - 6g x 30 mm)	(4)	96358	[SS]
135	Valve Housing	(1)	96334-1	[A]
136	Plug	(1)	96335	[A]
✓ 137	"O" Ring (1/16" x 2" o.d.)	(1)	Y325-32	[B]
✓ 138	"U" Cup (3/16" x 1.792" o.d.)	(1)	95966	[B]
✓ 139	"U" Cup (3/16" x 1-1/4" o.d.)	(1)	Y186-50	[B]
140	Valve Insert	(1)	95650	[Ck]
141	Valve Plate	(1)	95659	[Ck]
✓ 166	Track Gasket	(1)	94026	[B]
✓ 167	Pilot Assembly (includes 168 and 169)	(1)	67164	[D]

#### MATERIAL CODE

[A] = Aluminum	[Ck] = Ceramic	[Sp] = Santoprene
[B] = Nitrile	[D] = Acetal	[SS] = Stainless Steel
[Br] = Brass	[I] = Cast Iron	[U] = Polyurethane
[C] = Carbon Steel		

### AIR MOTOR SECTION SERVICE

Service is divided into two parts - 1. Pilot Valve, 2. Major Valve.

#### GENERAL REASSEMBLY NOTES:

- Air Motor Section service is continued from Fluid Section repair.
- Inspect and replace old parts with new parts as necessary. Look for deep scratches on metallic surfaces, and nicks or cuts in "O" rings.
- Take precautions to prevent cutting "O" rings upon installation.
- Lubricate "O" rings with Lubriplate FML-2 grease.
- Do not over-tighten fasteners. Refer to torque specification block on view.
- Re-torque fasteners following restart.
- SERVICE TOOLS - To aid in the installation of (168) "O" rings onto the (167) pilot piston, use tool # 204130-T, available from ARO.

#### PILOT VALVE DISASSEMBLY

1. A light tap on (118) should expose the opposite (121) sleeve, (167) pilot piston and other parts.
2. Remove (170) sleeve. Inspect inner bore of sleeve for damage.

#### PILOT VALVE REASSEMBLY

1. Clean and lubricate parts not being replaced from service kit.

Item	Description (size)	Qty	Part No.	[Mtl]
168	"O" Ring (3/32" x 5/8" o.d.)	(2)	94433	[U]
169	"U" Cup (1/8" x 7/8" o.d.)	(1)	Y240-9	[B]
170	Piston Sleeve	(1)	94081	[Br]
✓ 171	"O" Ring (3/32" x 1-1/8" o.d.)	(1)	Y325-119	[B]
✓ 172	"O" Ring (1/16" x 1-1/8" o.d.)	(1)	Y325-22	[B]
✓ 173	"O" Ring (1/16" x 1-3/8" o.d.)	(2)	Y325-26	[B]
★ ✓ 174	"O" Ring (1/8" x 1/2" o.d.)	(2)	Y325-202	[B]
✓ 176	Diaphragm (check valve)	(2)	94102	[Sp]
✓ 199	Track Gasket	(1)	95666	[B]
✓ 200	Gasket	(1)	95665	[B]
201	Muffler (includes item 127)	(1)	94810	
233	Adapter Plate	(1)	96336	[A]
240	Screw (M6 x 1 - 6g x 16 mm)	(2)	95991	[SS]
✓ 241	Track Gasket	(1)	96344	[B]
✓ 242	"O" Ring (1/16" x 7/32" o.d.)	(1)	Y325-5	[B]
✓ 243	"O" Ring (1/8" x 5/8" o.d.)	(1)	Y325-204	[B]
✓ 244	"O" Ring (1/8" x 7/8" o.d.)	(1)	Y325-208	[B]
★ ✓	Lubriplate FML-2 grease	(1)	94276	
	Lubriplate grease packets	(10)	637308	

★ Indicates items included in 637303-TA fluid section repair kit.

2. Install new (171 and 172) "O" rings. Replace (170) sleeve.
3. Install new (168) "O" rings and (169) seal - Note lip direction. Lubricate and replace.
4. Reassemble remaining parts. Replace (173 and 174) "O" rings.

### MAJOR VALVE DISASSEMBLY

1. Remove (135) valve block and (233) adapter plate, exposing (166 and 132) gaskets and (176) checks.
2. Remove (233) adapter plate, releasing (140) valve insert, (141) valve plate, (199, 200 and 241) gaskets and (243 and 244) "O" rings.
3. Remove (136) plug and (137) "O" ring, releasing (111) spool.

### MAJOR VALVE REASSEMBLY

1. Install new (138 and 139) "U" cups on (111) spool - **LIPS MUST FACE EACH OTHER.**
2. Insert (111) spool into (135) valve housing.
3. Install (137 and 242) "O" rings on (136) plug and assemble plug to (135) valve housing, securing with (105) screws.
4. Install (140) valve insert, (141) valve plate, (199) gasket and (243 and 244) "O" rings into (135) valve housing. NOTE: Assemble (140) valve insert with "dished" side toward (141) valve plate. Assemble (141) valve plate with part number identification toward (140) valve insert.
5. Assemble (200 and 241) gaskets and (233) adapter plate to (135) valve housing, securing with (240) screws.
6. Assemble (132 and 166) gaskets and (176) checks to (101) center body.
7. Assemble (135) valve housing and components to (101) center body, securing with (134) screws.

# PARTS LIST / 670106 AIR MOTOR SECTION

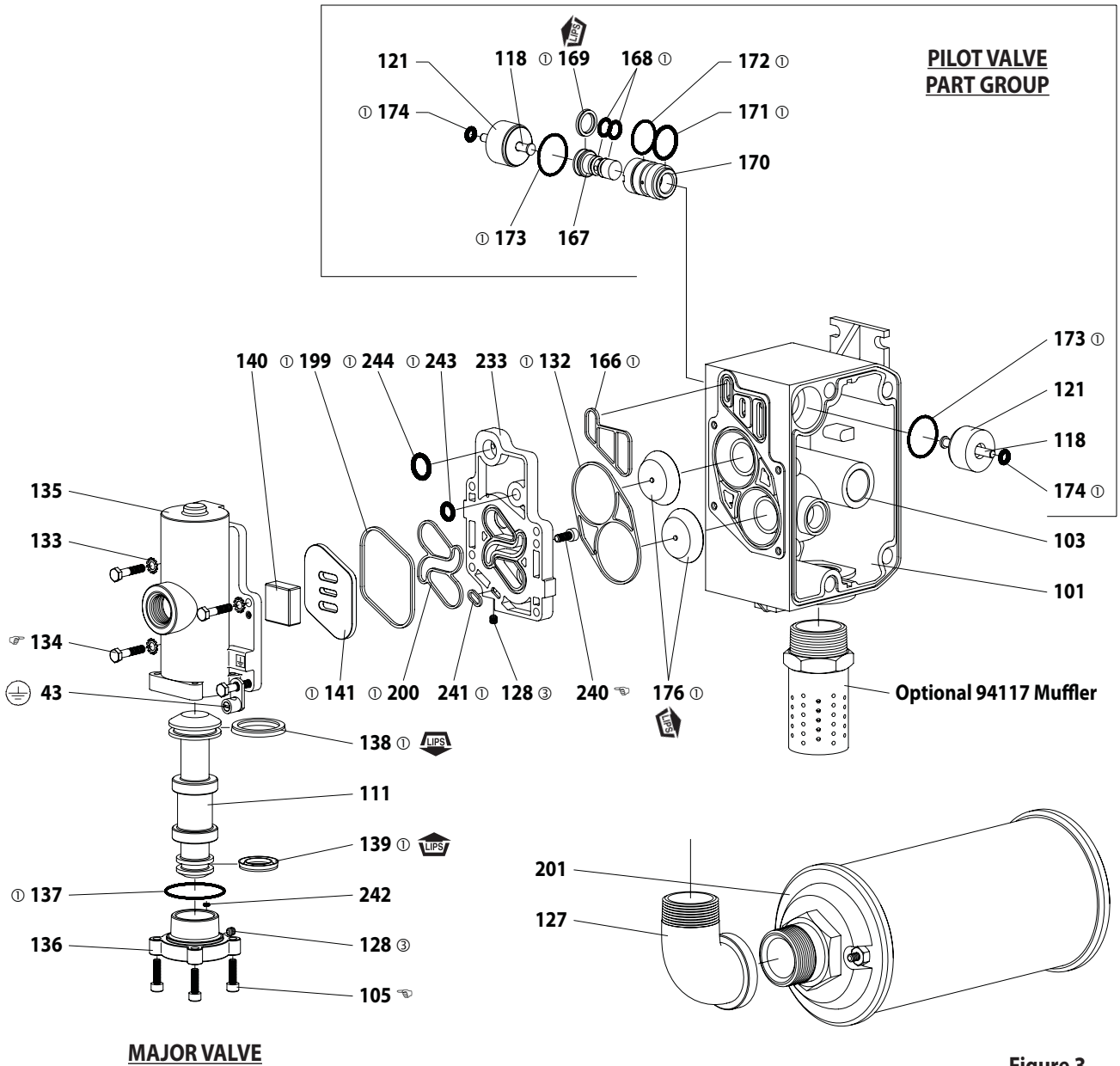

Figure 3

A 637374-2 replacement major valve service assembly is available separately, which includes the following:

105 (4), 111, 128 (2), 132, 133 (3), 134, 135, 136, 137, 138, 139, 140, 141, 166, 176 (2), 199, 200, 233, 240 (2), 241, 242, 243 and 244.

### ASSEMBLY TORQUE REQUIREMENTS

**NOTE: DO NOT OVERTIGHTEN FASTENERS.  
ALL FASTENERS ARE METRIC.**  
(105) screw, 40 - 50 in. lbs (4.5 - 5.6 Nm).  
(134) screw, 40 - 50 in. lbs (4.5 - 5.6 Nm).  
(240) screw, 40 - 50 in. lbs (4.5 - 5.6 Nm).

### LUBRICATION / SEALANTS

- ① Apply Lubriplate FML-2 grease to all "O" rings, "U" cups and mating parts.
- ③ Apply Loctite 271 to threads at assembly.

## TROUBLE SHOOTING

### Product discharged from exhaust outlet.

- Check for diaphragm rupture.
- Check tightness of (6) diaphragm screw.

### Air bubbles in product discharge.

- Check connections of suction plumbing.
- Check "O" rings between intake manifold and fluid caps.
- Check tightness of (6) diaphragm screw.

### Motor blows air or stalls.

- Check (176) check valve for damage or wear.
- Check for restrictions in valve / exhaust.

### Low output volume, erratic flow or no flow.

- Check air supply.
- Check for plugged outlet hose.
- Check for kinked (restrictive) outlet material hose.
- Check for kinked (restrictive) or collapsed inlet material hose.
- Check for pump cavitation - suction pipe should be sized at least as large as the inlet thread diameter of the pump for proper flow if high viscosity fluids are being pumped. Suction hose must be a non-collapsing type, capable of pulling a high vacuum.
- Check all joints on the intake manifolds and suction connections. These must be air tight.
- Inspect the pump for solid objects lodged in the diaphragm chamber or the seat area.

## DIMENSIONAL DATA

Dimensions shown are for reference only, they are displayed in inches and millimeters (mm).

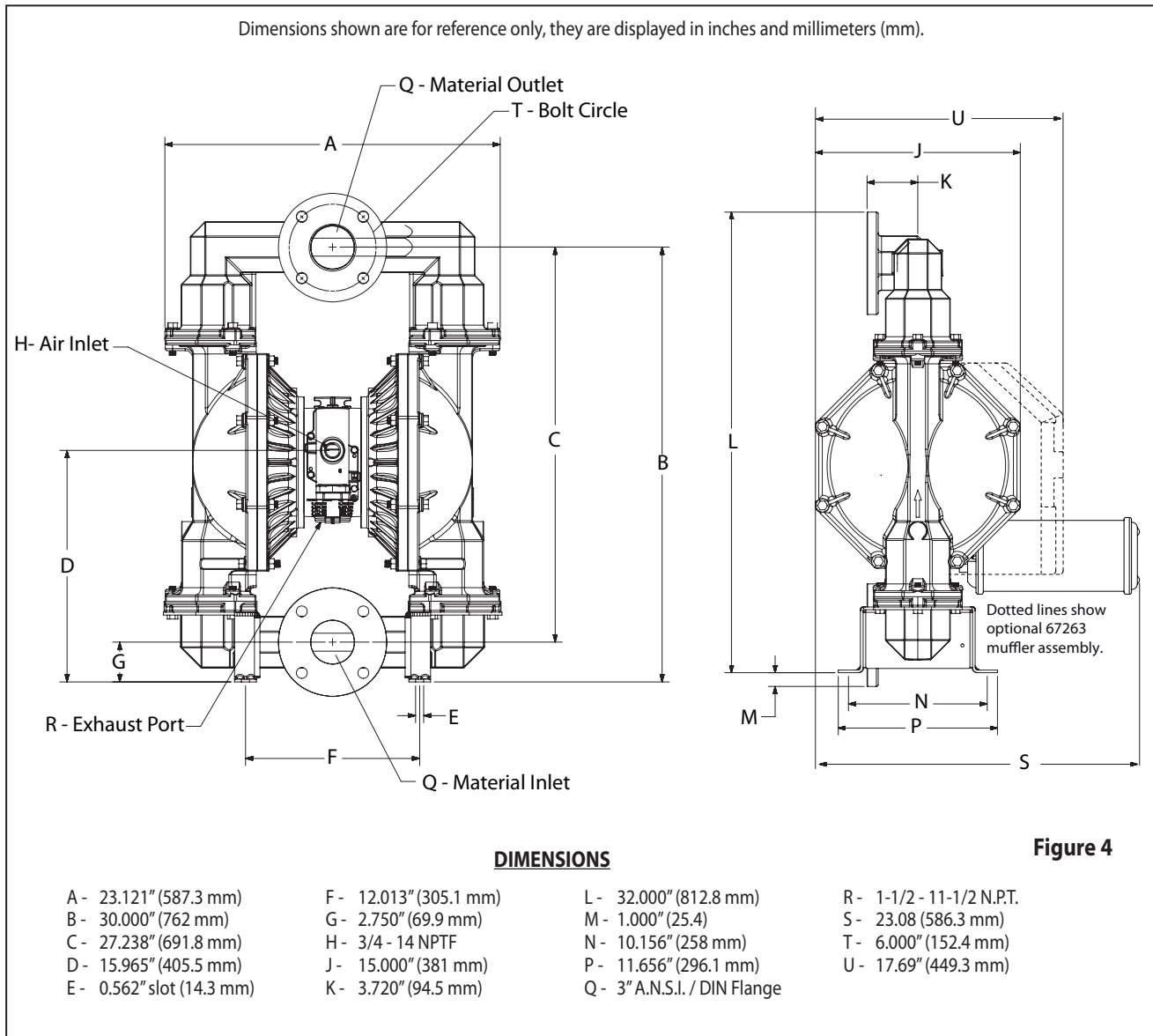

**Figure 4**